

Title: RPi3.SchDoc

Desc: :

Size: Usletter | **Auth:** | **Proj:**

Date: 12/15/2021 | **Time:** 8:23:47 PM | **Sheet:** 1 of 3

Repo:

File: C:\Users\Public\Documents\Altium\CAN Test Hat\RPi3.SchDoc



open source hardware

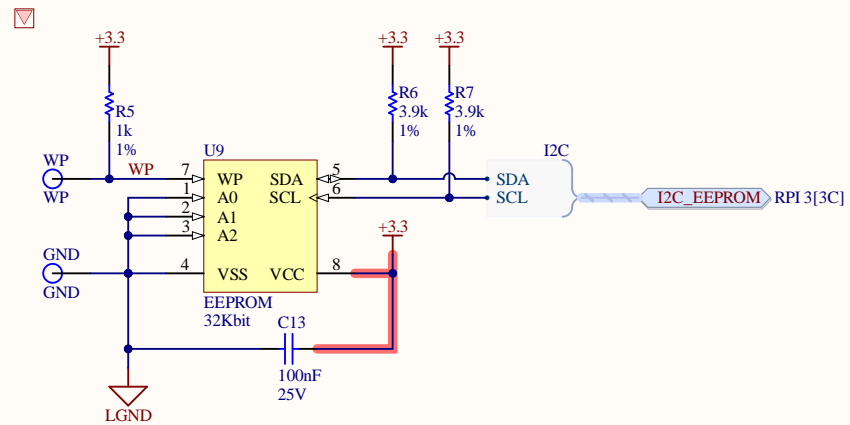

Title: ID EEPROM.SchDoc		
Desc: :		
Size: US Letter	Auth:	Proj:
Date: 12/15/2021	Time: 8:23:47 PM	Sheet 2 of 3
File: C:\Users\Public\Documents\Altium\CAN Test Hat\ID EEPROM.SchDoc		



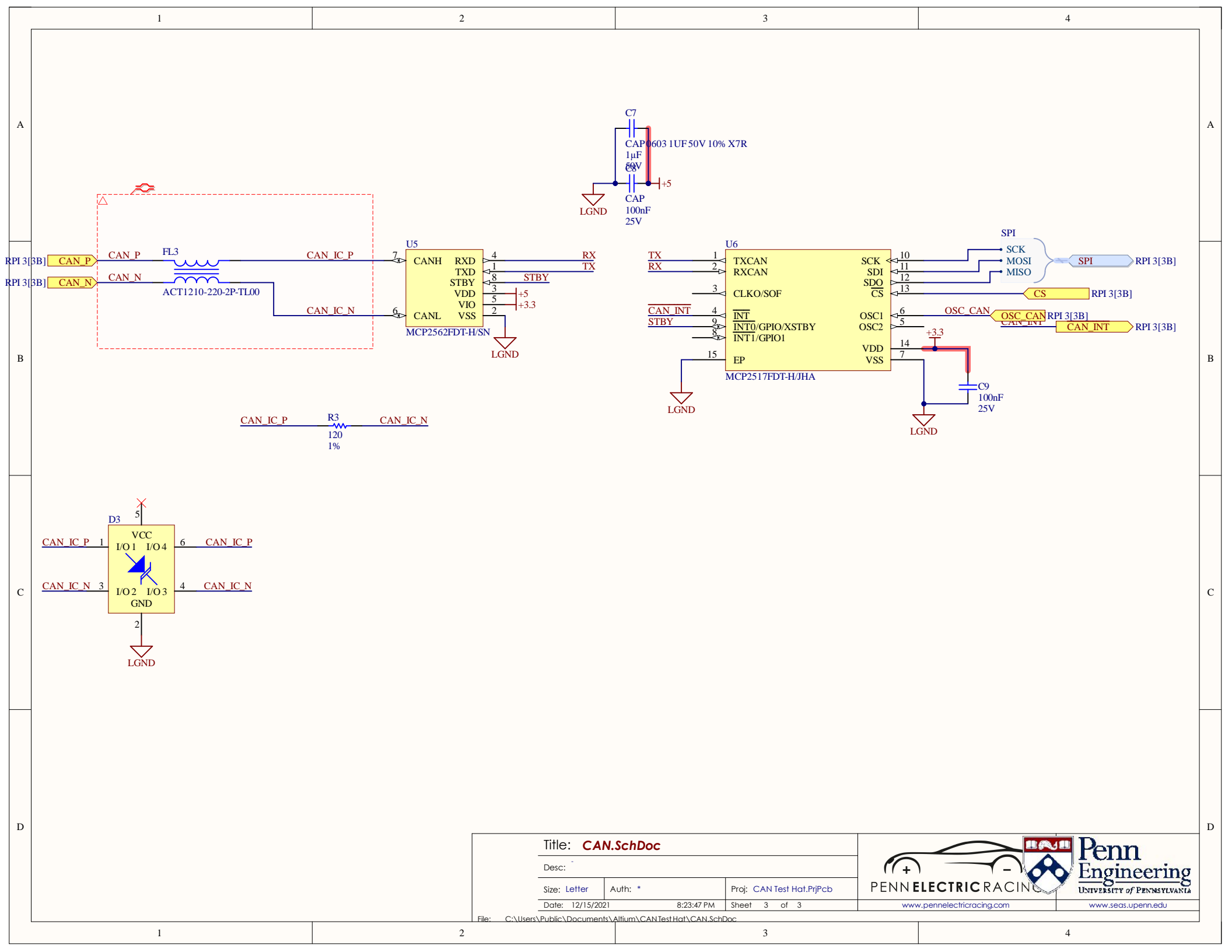

Title: **CAN.SchDoc**

Desc:

Size: Letter

Auth: *

Proj: CAN Test Hat.PjtPcb

Date: 12/15/2021

8:23:47 PM

Sheet 3 of 3



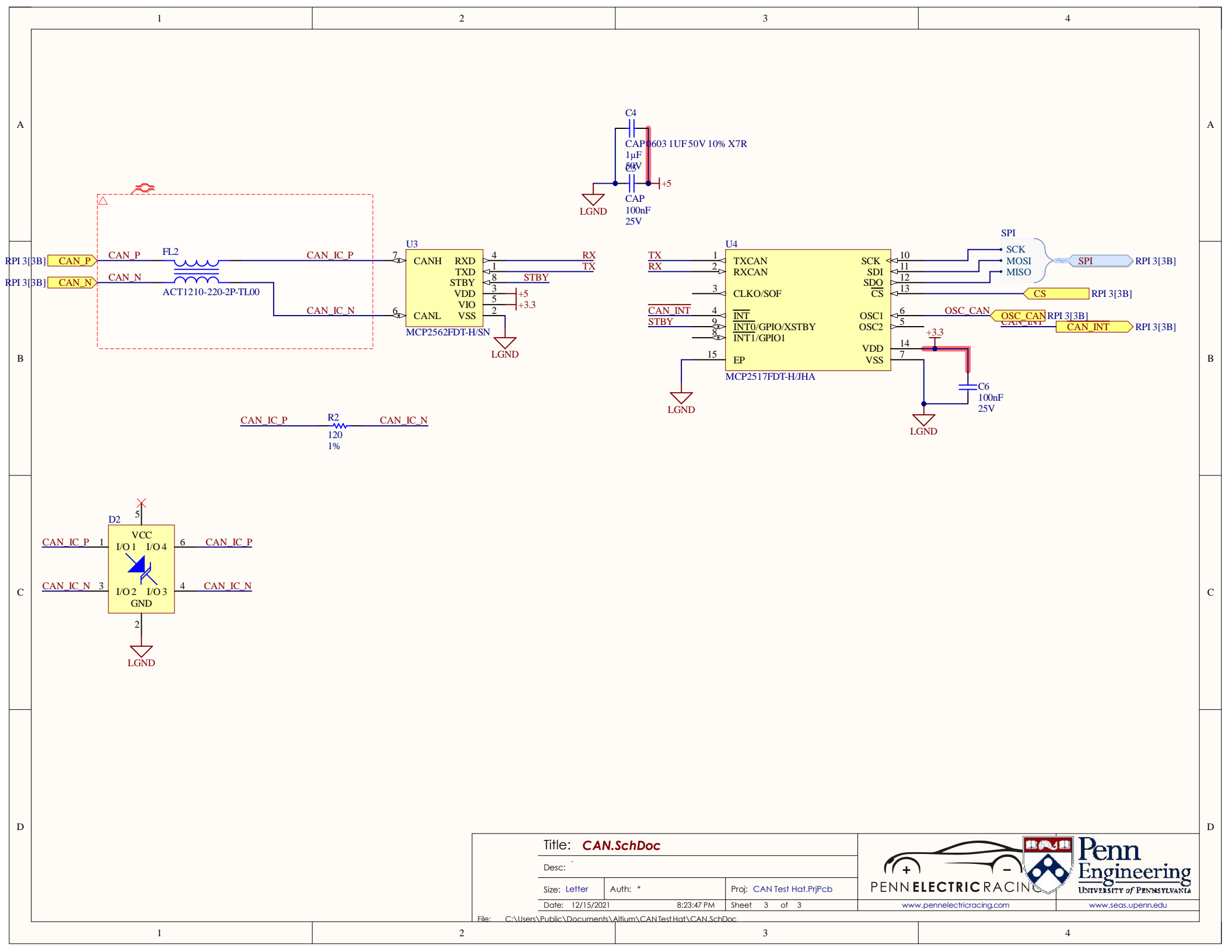

Title: **CAN.SchDoc**

Desc:

Size: Letter

Auth: *

Proj: CAN Test Hat.PriPcb

Date: 12/15/2021

8:23:47 PM

Sheet 3 of 3



www.pennelectricracing.com

www.seas.upenn.edu

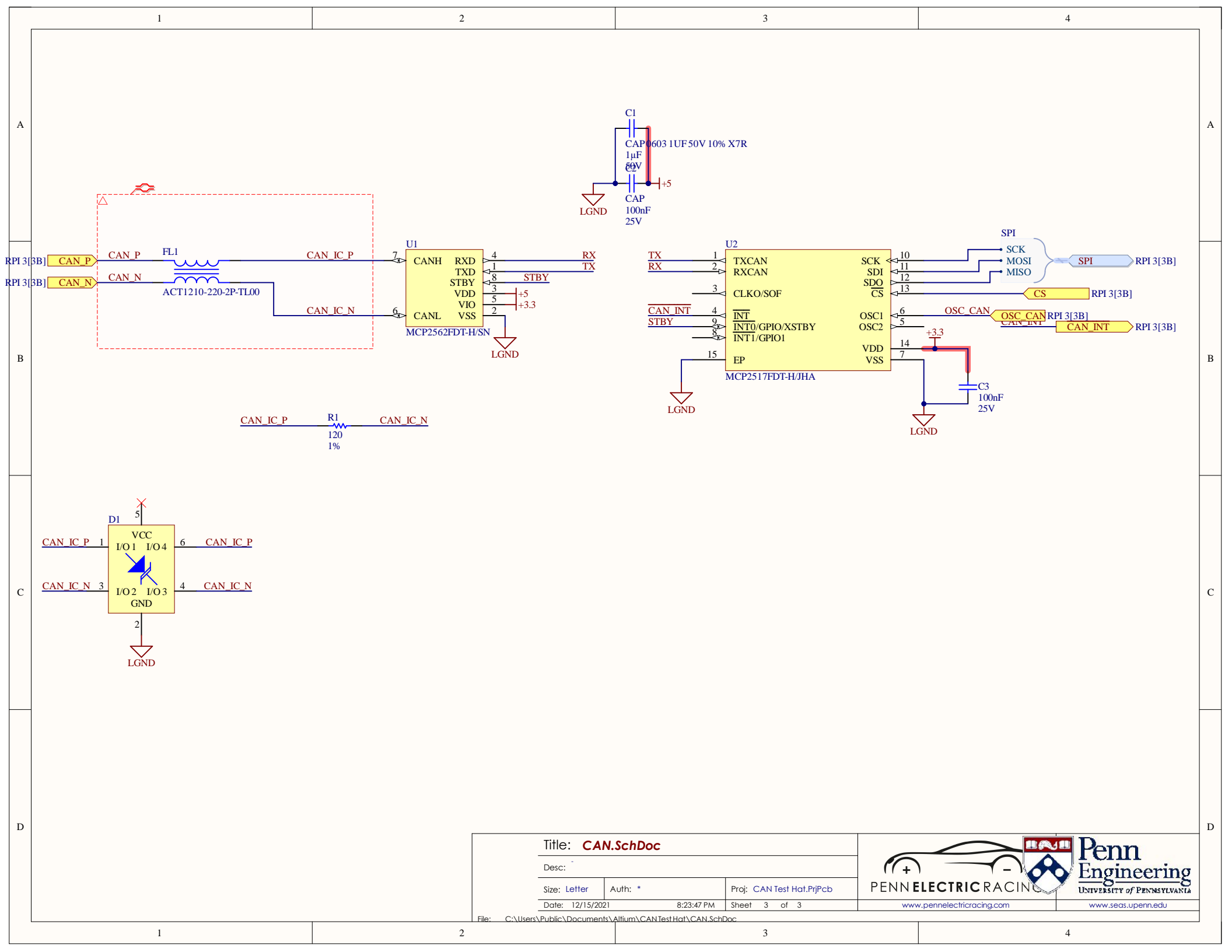

Title: **CAN.SchDoc**

Desc:

Size: Letter

Auth: *

Proj: CAN Test Hat.PjtPcb

Date: 12/15/2021

8:23:47 PM

Sheet 3 of 3



www.pennelectricracing.com

www.seas.upenn.edu

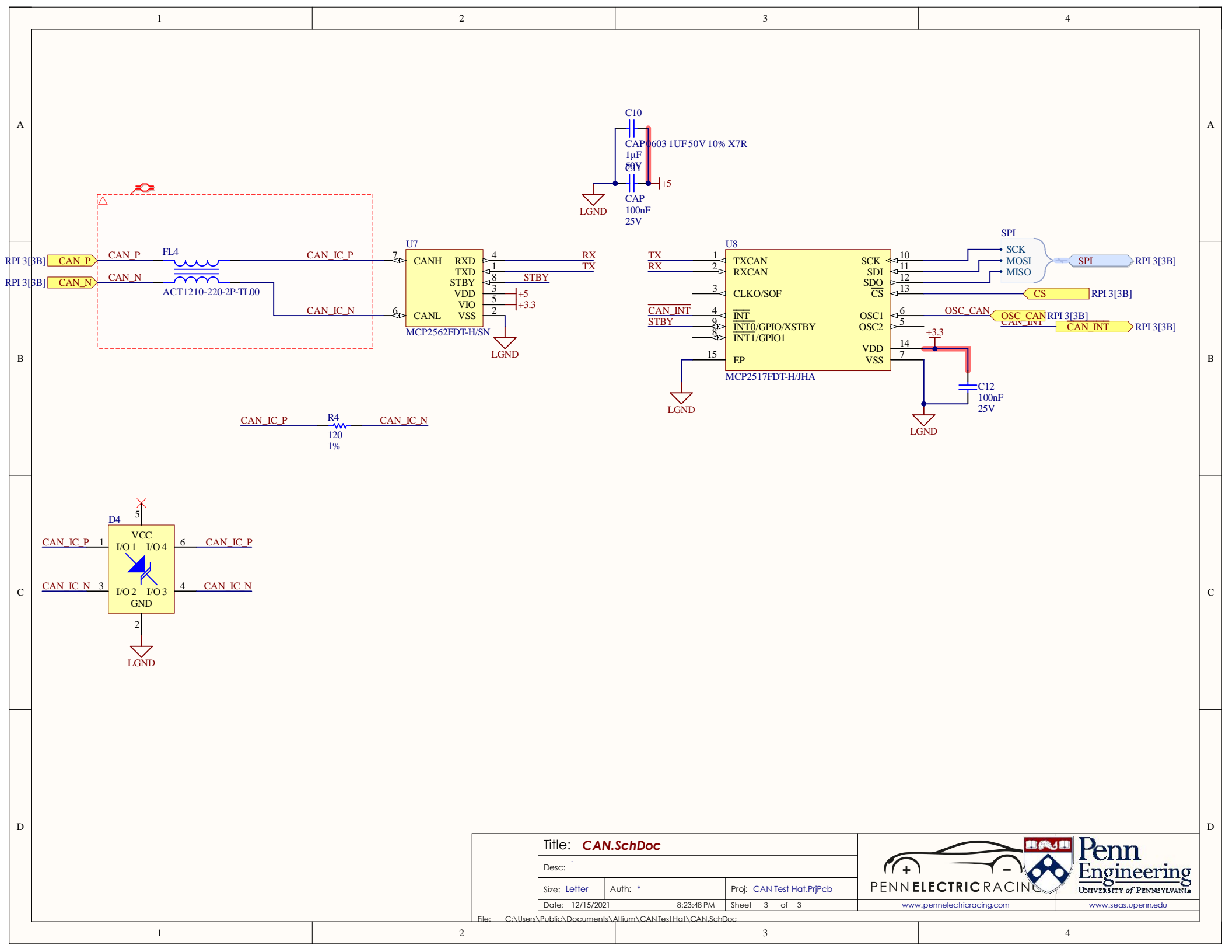

Title: **CAN.SchDoc**

Desc:

Size: Letter

Auth: *

Proj: CAN Test Hat.PjtPcb

Date: 12/15/2021

8:23:48 PM

Sheet 3 of 3



www.pennelectricracing.com

www.seas.upenn.edu